

**Aircraft**  
*interiors*  
**EXPO 2006**  
HAMBURG 4, 5, 6 APRIL

[www.aircraftinteriors-expo.com/hamburg](http://www.aircraftinteriors-expo.com/hamburg)

**OPEN CONCEPTS & IDEAS FORUM**

At the Open Forum in Hall 2 on 4 and 6 April 2006

# FRP springs for lightweight applications

Prof. Dr. Gerhard Scharr, Martin Hoffmann

University of Rostock





**FRP-Parts of the Airbus A380**

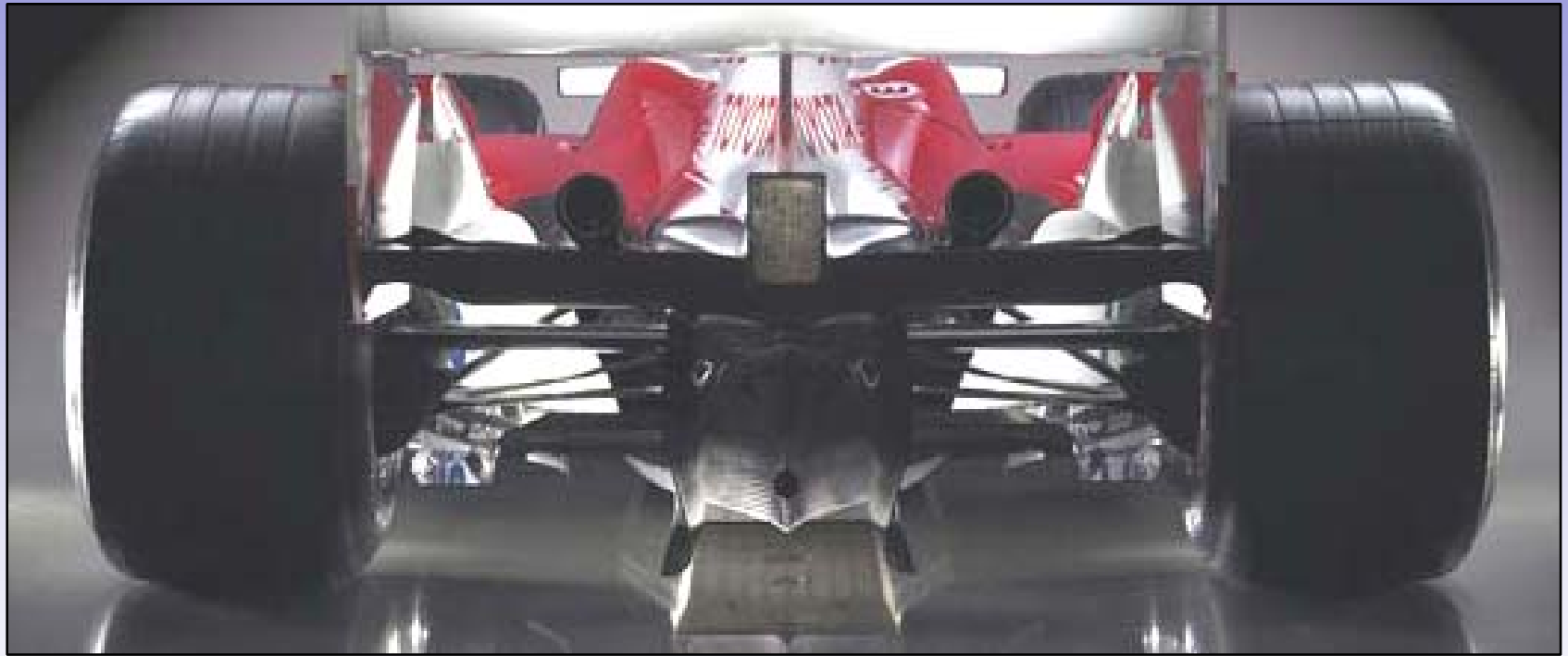

**F1-car wheel suspension**

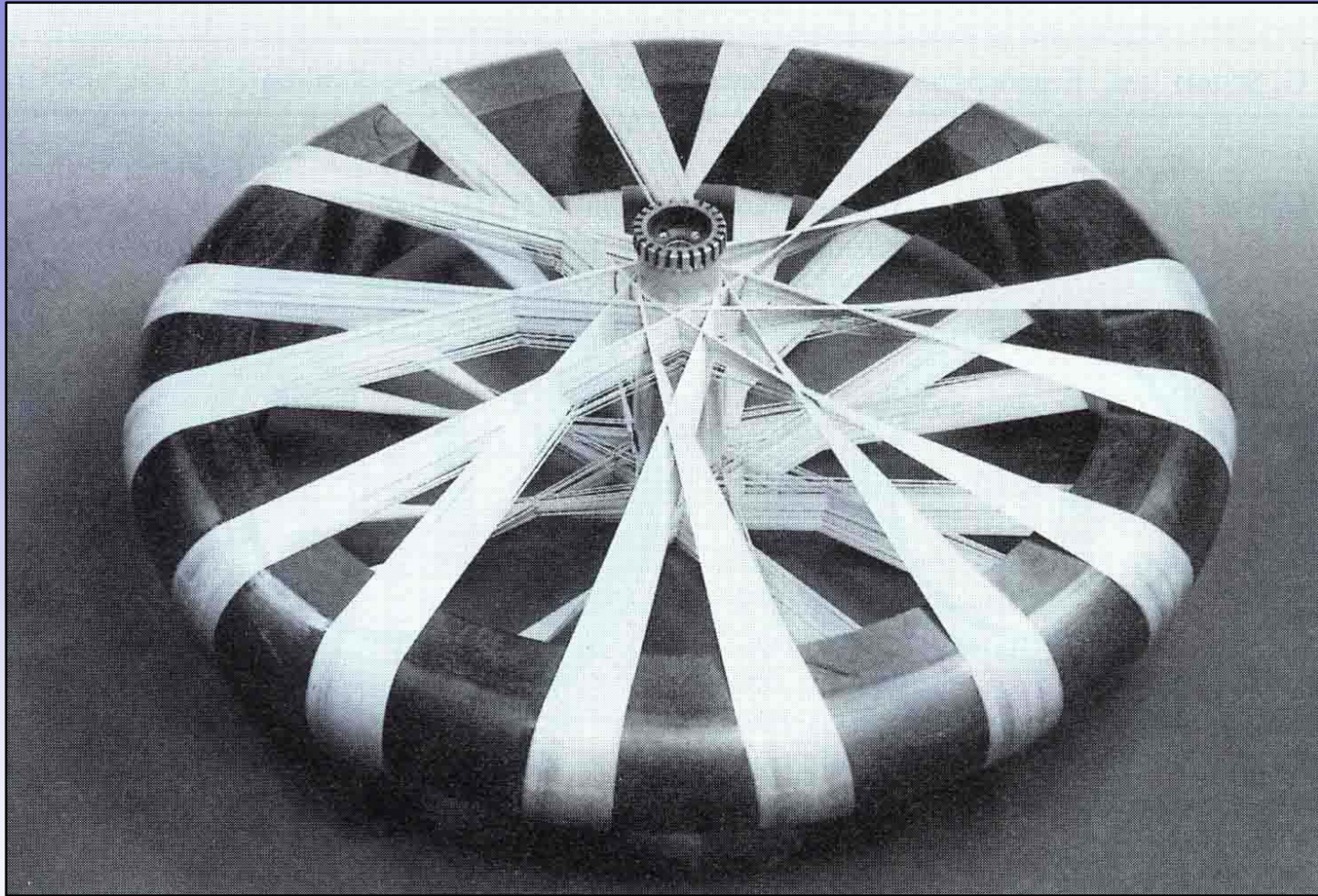

**Flywheel with aramidfibre torque arms**

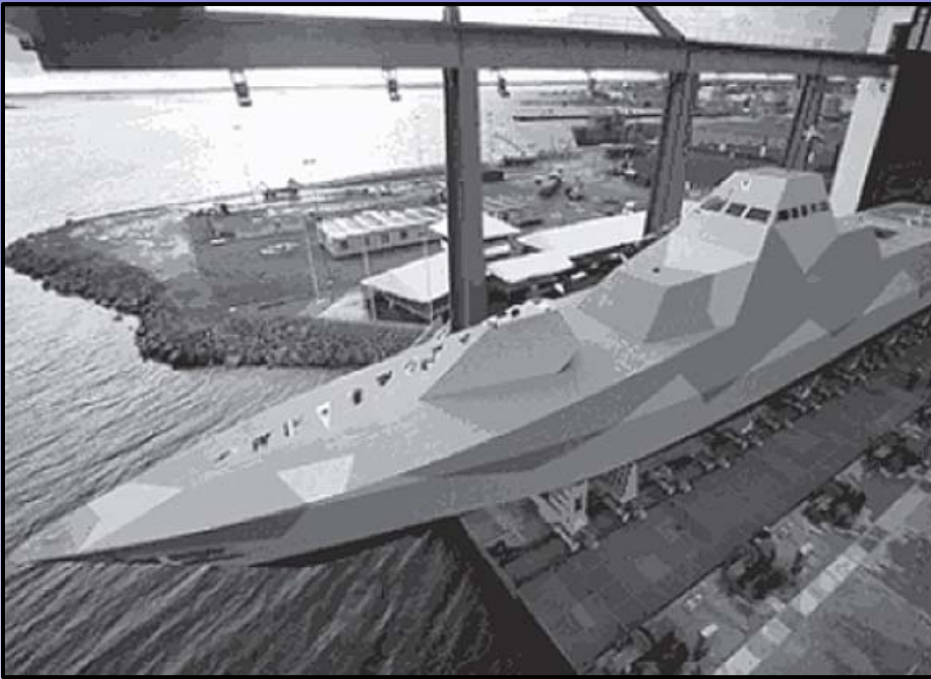

**Swedish stealth corvette  
„Visby“ made of GFRP**

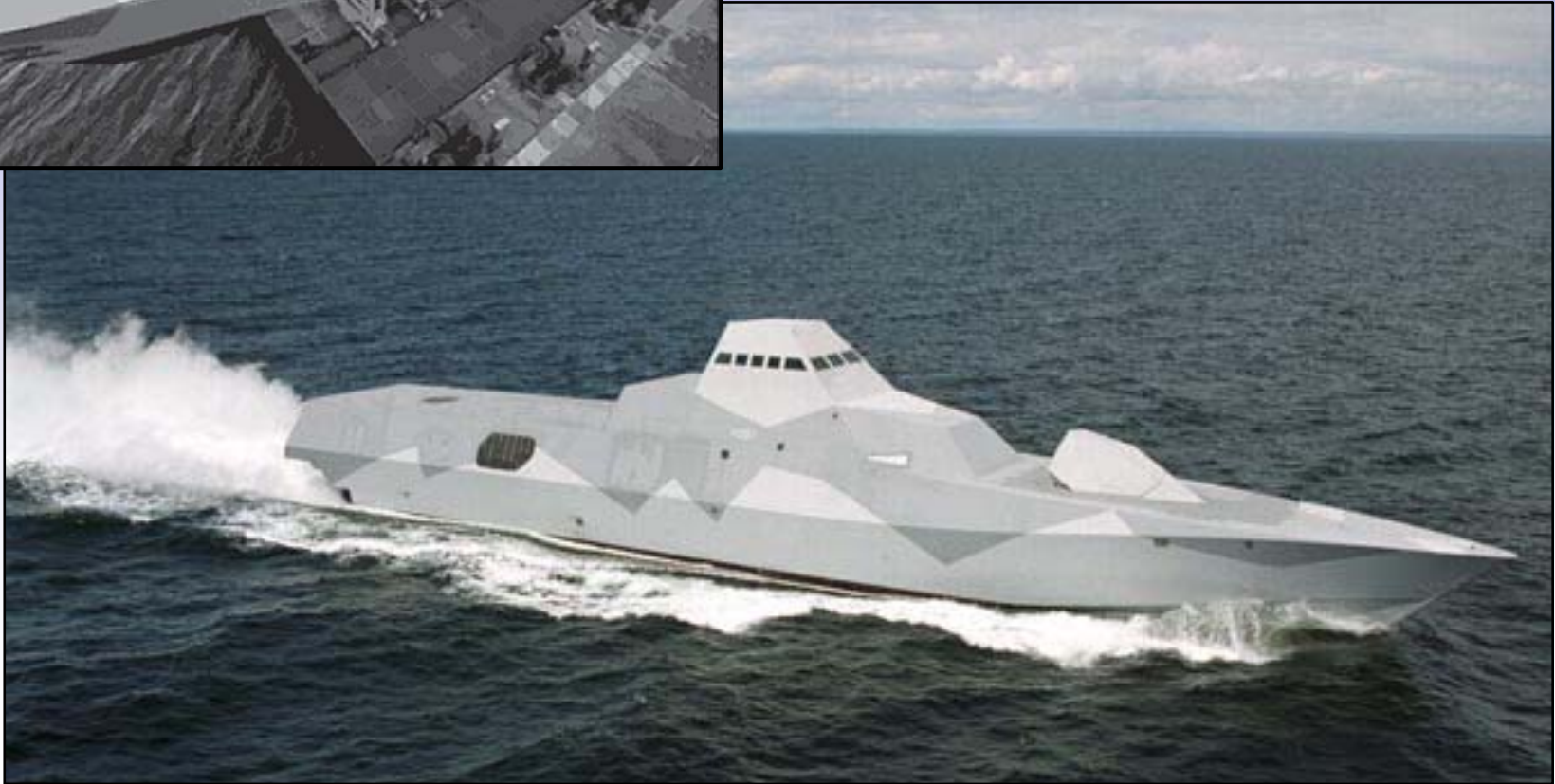



**Roboter with a CFRP arm**



**Pole vault with GFRP pole**



**Wind turbines with GFRP rotor blades**



**CFRP leg amputation appliance**



**GFRP Sport bow**



**GFRP leaf spring**



**CFRP foot amputation appliance**

## Advantages and Disadvantages of FRP-springs

### Advantages:

- high resilience
- low creep
- high specific strength
- high specific modulus
- good 'fail safe' behaviour
- high damping
- good corrosion resistance
- low thermal extention
- spring rate independent  
of temperature and frequency

### Disadvantages:

- cost
- calculation
- industrial scale manufacture
- monitoring / Testing
- recycling



**CFRP engine mount**

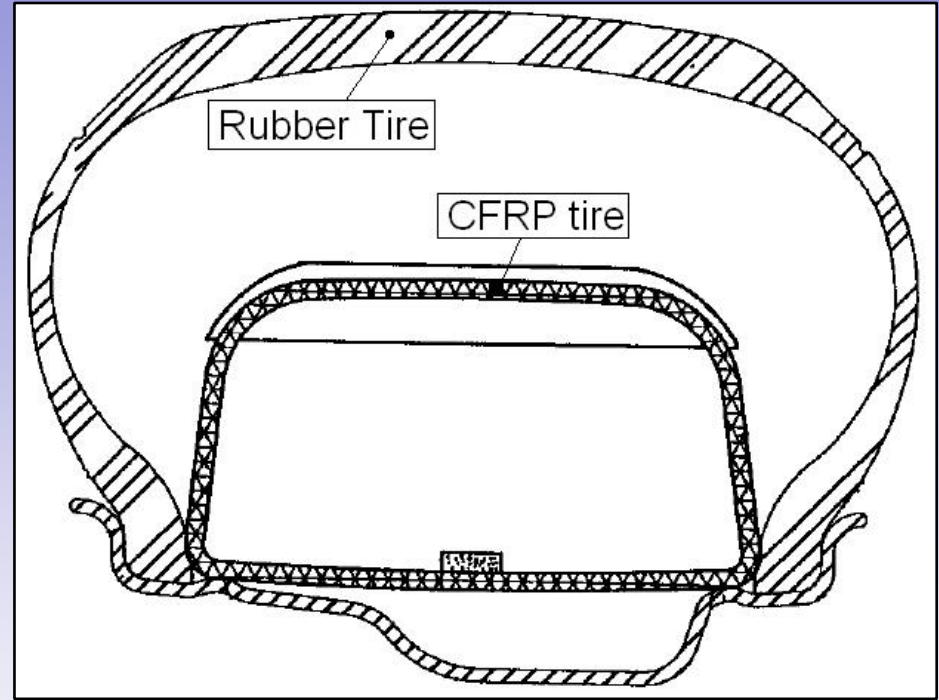

**CFRP flat run system**



**Unpressurized tire with CFRP spring**

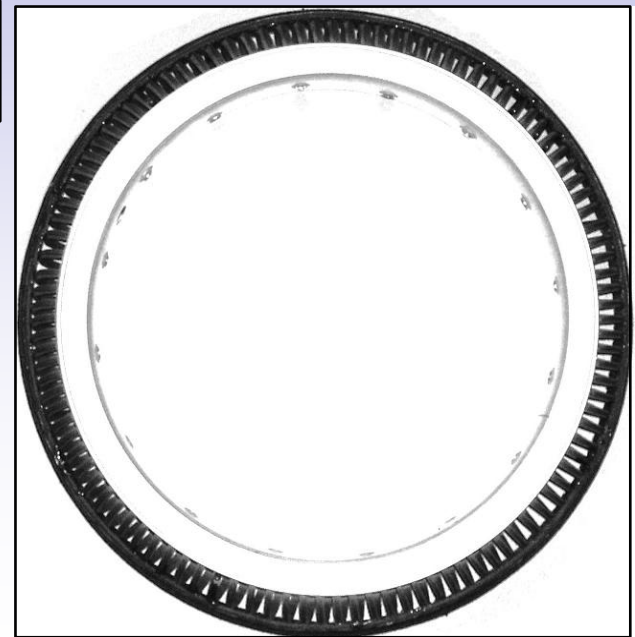
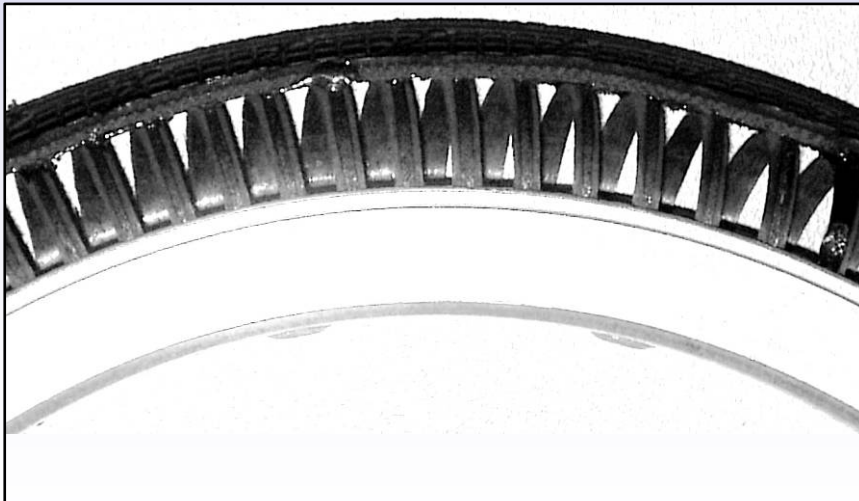



**CFRP friction spring (CAD simulation/photo)**

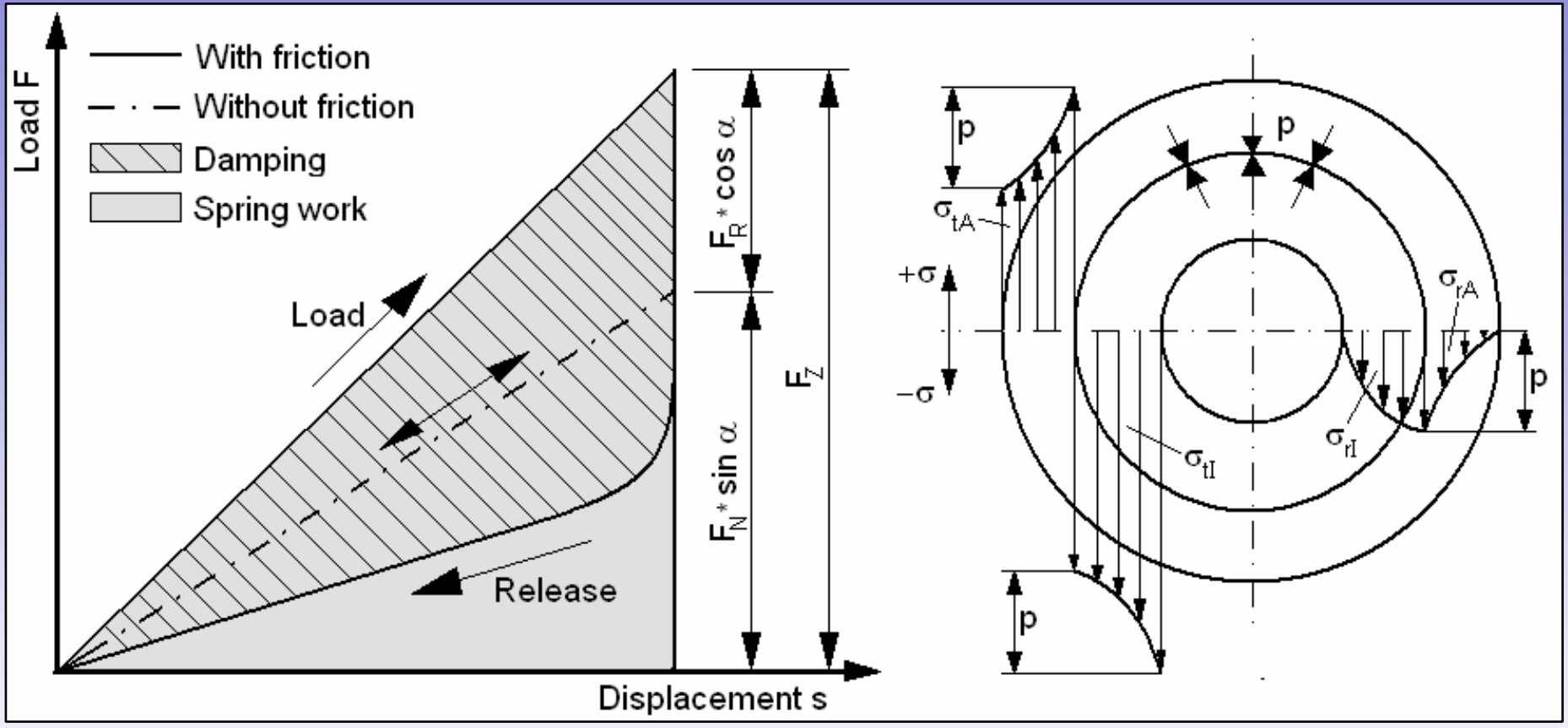

**Spring characteristics / stress conditions**

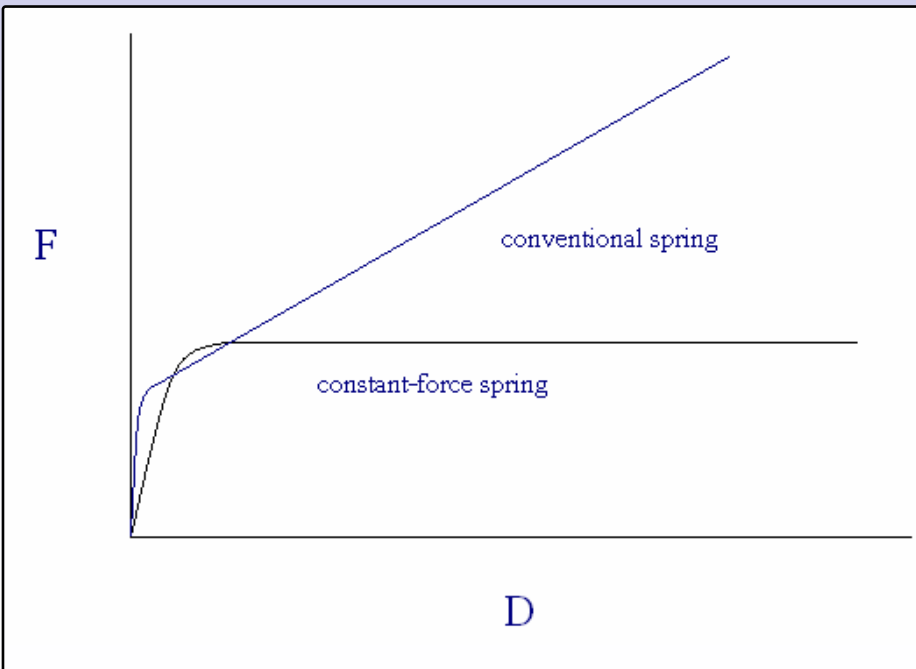
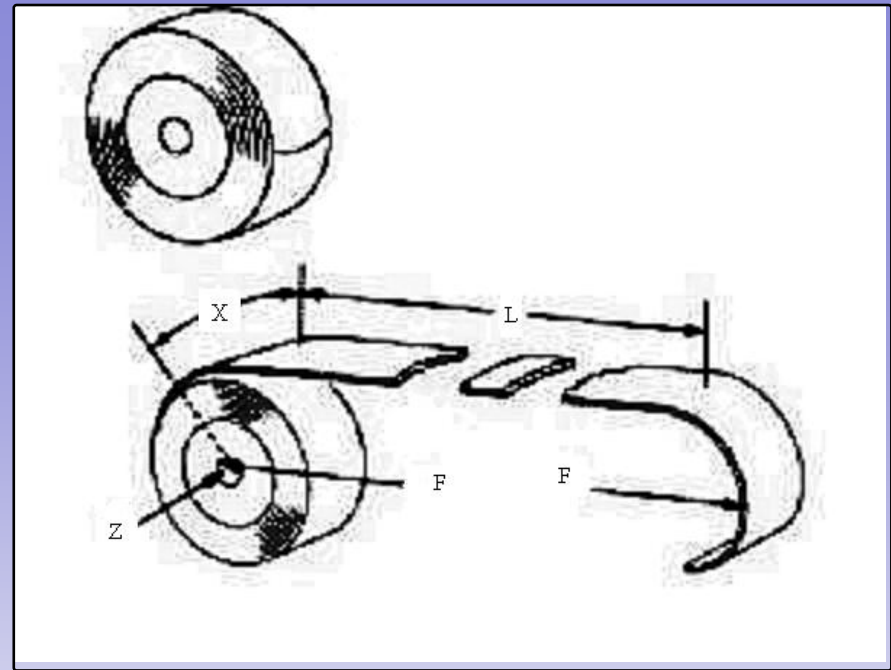

## CFRP Constant Force Spring

Thank you  
for your  
attention!