



Aerospace Testing Conference
November 2005

What is it?

ViaSat

What Is A Virtual Communications Environment?

Using high-performance computing and signal generation resources a controlled RF environment that mimics the operational RF environment can be created for concept development test, evaluation, and training

The Potential Advantages of Testing In A Virtual Communications Environment

T& E Risk Reduction

- 24/7 Availability
- Test Strategy
 - Improve
 - Reduce
 - Verify

Fidelity

- Signal Accuracy
 - Signal Density
 - Signal Variety

Test Conditions

- Controllable
 - Repeatable
 - Predictable

Programmable

- Realism
 - Flexibility
 - Extensibility



Bands of Interest

- Any band used for RF communications...
 - ◆ Typically includes digital and analog communications
 - ◆ Includes communication, navigation, and combat identification type functions.

Band	Frequency	Wavelength	Function
MF	300-3000kHz	1000-100m	AM radio
HF	3-30MHz	100-10m	CB, HF COMM
VHF	30-300MHz	10-1m	FM radio, ATC comm, VHF Comm, Secure Comm, TV channels 2-13
UHF	300-3000MHz	100-10cm	Secure Comm, TV channels 14-69
SHF	3-30GHz	10-1cm	
EHF	30-300GHz	10-1mm	

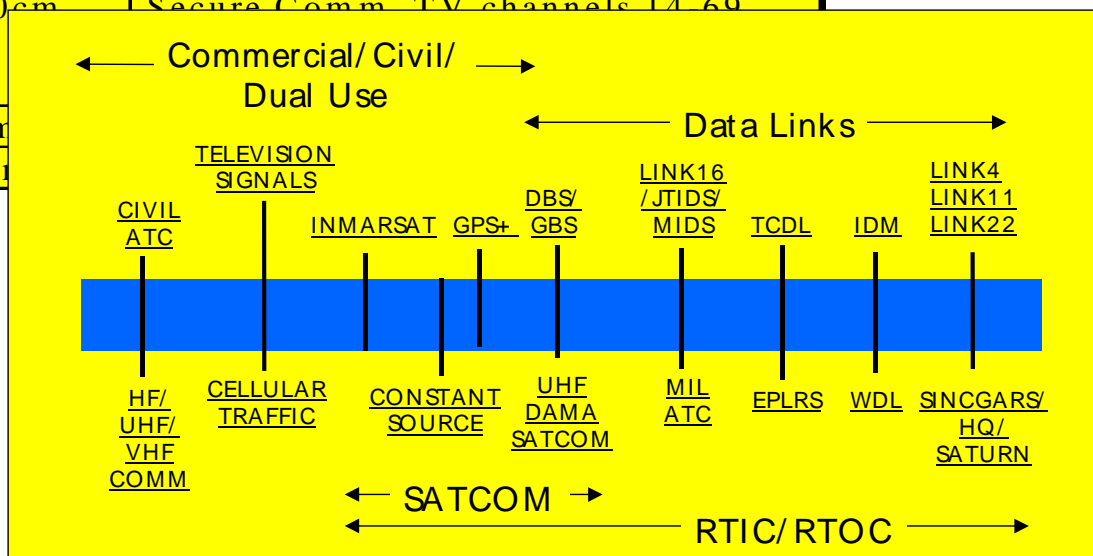

Overview

ViaSat

- **Objectives of a cost effective Virtual RF Test Bench Environment utilizing a modular, scalable approach**
 - ◆ Minimizes cost and risk
 - ◆ Minimize redefinition of software states and modes while maintaining flexibility
- **Additional waveforms added without significant impact to Hardware**
- **Model Air Traffic communication traffic loads of realistic operational scenarios (flight plan)**
- **Performance evaluation of throughput and delay of aeronautical sub networks under load**
- **Support repeatable experimental trials**

Air Traffic Environment



Air Traffic LA Basin

ViaSat

- **Based on FAA Data derived from current website materials**
 - ◆ Aircraft density for the year 2015 is predicted to be 1,110,684
 - This represents a 2% growth over 2014
 - This factor was applied through the year 2020 for a total of 1,228,741
 - The number was converted to an average of about 200 aircraft per hour

The year 2020 will see an average of 200 aircraft per hour
Or 1,228,741 total flights in the basin

Top Level Architecture

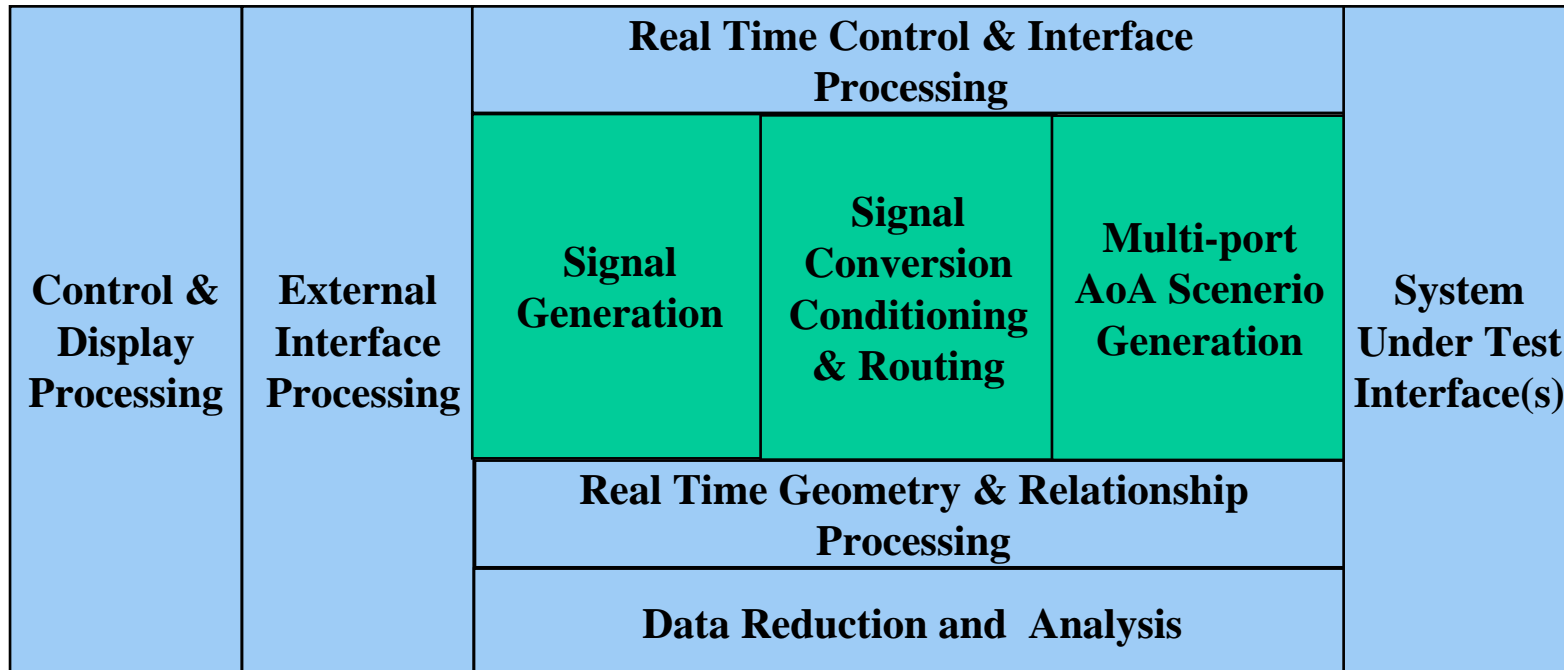

Modular, Scalable Architecture

Key Features

ViaSat

- **Realistic Mix of Signals**
 - ◆ Environment filled with independent RF sources
 - ◆ Sources placed with physical resources including frequency, modulation, ERP, antenna patterns and content
 - ◆ Terrain characteristics
- **Full Run Time Control**
 - ◆ Operator intervention to instantly change environment
 - ◆ Enable or disable any individual emitters carrier frequency, ERP or message rate
 - ◆ Controlled movement of platforms including dynamic movement
- **Capability to present almost any type of signal simulation**
 - ◆ Up to 10 mega symbols per second in combination with any other signal set
 - ◆ Creates realistic operational environment prior to operational status
 - ◆ Existing Waveform modifications tested prior to final implementation of changes

RF Virtual Environment



Signal Emphasis

ViaSat

- **Friendly and threat IFF, NAV, ATC, Communications**
 - ◆ High Fidelity Timing/Interaction Model (All inclusive)
 - ◆ Supports external modulation sources
 - ◆ Medium Fidelity Resolution (50 ns - coarse)
- **Threat data links**
 - ◆ High Fidelity Modulation (programmable BIT Clock)
 - ◆ High Fidelity Integrated Air Defense System simulation
- **Early warning radars**
 - ◆ Simple/Slow Rotating Antennas or Fixed
 - ◆ Low PRF, Simple PRI (no jitter)
 - ◆ Currently no multimode or complex scan capability
- **Attenuation and phase control per channel**
 - ◆ Hi Fidelity AoA (.25dB/1°), Med. Fidelity Non-AoA (1dB)

■ RF Signal Generation

- ◆ 500 kHz to 18 GHz Non-AoA
- ◆ 20 MHz to 2 GHz AoA
- ◆ Programmable Signal Sources (HFPPM)
 - Generate analog, digital & multiple modulations
 - Modulation BW from CW to 20 MHz
 - Analog examples: AM, FM, SSB, DSB Quadrature AM, Noise
 - Digital examples: BPSK, p/4-DQPSK, FSK, BASK, 128 QAM, D8PSK
- ◆ AoA can support interferometers of up to 32 ports with relative phase and amplitude
- ◆ -20 dBm maximum output power

Signal Manipulation

ViaSat

- **Geometry and Relationship Modeling Accurately Simulates Effects of Platform Dynamics**
 - ◆ Propagation Delay, Path Loss, Doppler, Antenna Directivity/polarization
 - ◆ Angle Of Arrival (AoA) Phase and Amplitude Conditioning
 - ◆ Coherent Simulation of Wideband and Narrowband Emitters
- **Signal Manipulation**
 - ◆ Off Center Frequency
 - ◆ Modulation errors
 - ◆ Changes to noise characteristics
- **Jamming**
 - ◆ Self Jamming and co-site issues
 - ◆ Adjacent channel interferers
 - ◆ Broadband and harmonic interferers
- **Signal Characteristics altered to Test units to failure**

Signal Coherency

ViaSat

- ◆ Model Coherency
 - Embedded Data
 - Signal Loading and Timing
 - Voice or Tones
- ◆ Network Layer Simulation (Multi-ship or Multi-node Operations)
 - Data Link Loading
 - Data Link Timing



Concept of Operations



Operational Objectives

ViaSat

- **Functional Integration**
- **Signal Stimulation and noise environment**
 - ◆ Up to 2000 emitters, 400 moving
 - ◆ Range, pointing angles and closure rate calculated between all virtual platforms and SUT, used to calculate effects such as Doppler.
 - ◆ Transmit/receive antenna patterns, beyond line of sight status and link equation used to calculate signal power at the SUT for all emitters.
- **Man in the loop scenario generation (Hardware in the Loop support)**
 - ◆ Realistic flight environment with Pilot interfaces
- **Automated control of functional tests**
- **Automated data collection of test results**
 - ◆ Test repeatability for verification or Acceptance Test of Systems
- **System level integration debug capabilities**
- **Hardware in the Loop/Functional simulations/functional SW-HW integration all accomplished with common interface and control structures**
- **Support End to End testing of Systems and Apertures**

Simulation Capabilities

ViaSat

- **Air Traffic Management State machine based behavioral modeling can drive communication and Scenario Progression**
- **Preprogrammed scenarios allow scripted tests of up to 12 hours in length**
 - ◆ Repeatable Scripting
- **Operator (or Pilot) in the loop for interactive testing**
 - ◆ Real time intervention and changes in scenario of Unit under test
 - ◆ Real time intervention of other virtual players

Control Station Functionality

ViaSat

- **All Tests & Simulation Centrally Managed**
 - ◆ Recording and Management Element
 - Collection, analysis and Data Management system
 - ◆ User Control Element
 - Primary User Interface and Test Management
 - Graphical interface
 - Analysis and control interface for tests
 - ◆ SUT Monitoring/Injection Element
 - Interface to UUT for data monitoring, synchronization and data injection
 - Includes CMU interface and UUT Bus Monitoring/Injection
 - ◆ Scenario and Information Element
 - Simulation Environment Interface
 - Off-line Scenario Generator

Integration Capabilities

ViaSat

- **System-level monitoring and control**
- **Message Injection and Monitoring**
- **Automated Test Procedure Execution and control**
 - ◆ Message injection/monitor
 - ◆ Test equipment control
 - ◆ Data analysis and display
- **Manual message injection and monitoring control**
- **Extensive message and test sequence editing capability**
- **Test Equipment controlled remotely**
 - ◆ All user interfaces are controlled through System Command and Control executive
- **Extensive BIT and internal calibration support**

Qualification Testing Capabilities

ViaSat

- **Allows Test to Break Scenario's**
 - ◆ Altered Signal Characteristics
 - ◆ Significant Dense RF Environments
- **Automated Execution and control**
 - ◆ Repeatable for Individual signals as well as multi signal testing
 - ◆ Data capture of key performance elements
 - Data captured to allow key lower level specification elements to be tested or manipulated to determine system performance
- **Preprogrammed Scenario mode for test repeatability**
- **Interactive Virtual Flight Mode**



Benefits

ViaSat

- Robust research tool building advantage on previously developed simulation/stimulation tools
- Implementation of emerging aeronautical network protocol standards and the associated waveforms under real world conditions
- New Avionics and upgrades to current programs can be “stress” tested in a virtual flight environment to significantly reduce deployment risks
- Explore new ideas and concepts using both simulation capability as well as RF environment capability

