

F/A-18 E/F WEAPONS SEPARATION TESTING



CDR Eric J Mitchell

LT Terry Barrett

Mr. Jud Rupert, AIR 5.1.6.5



AGENDA

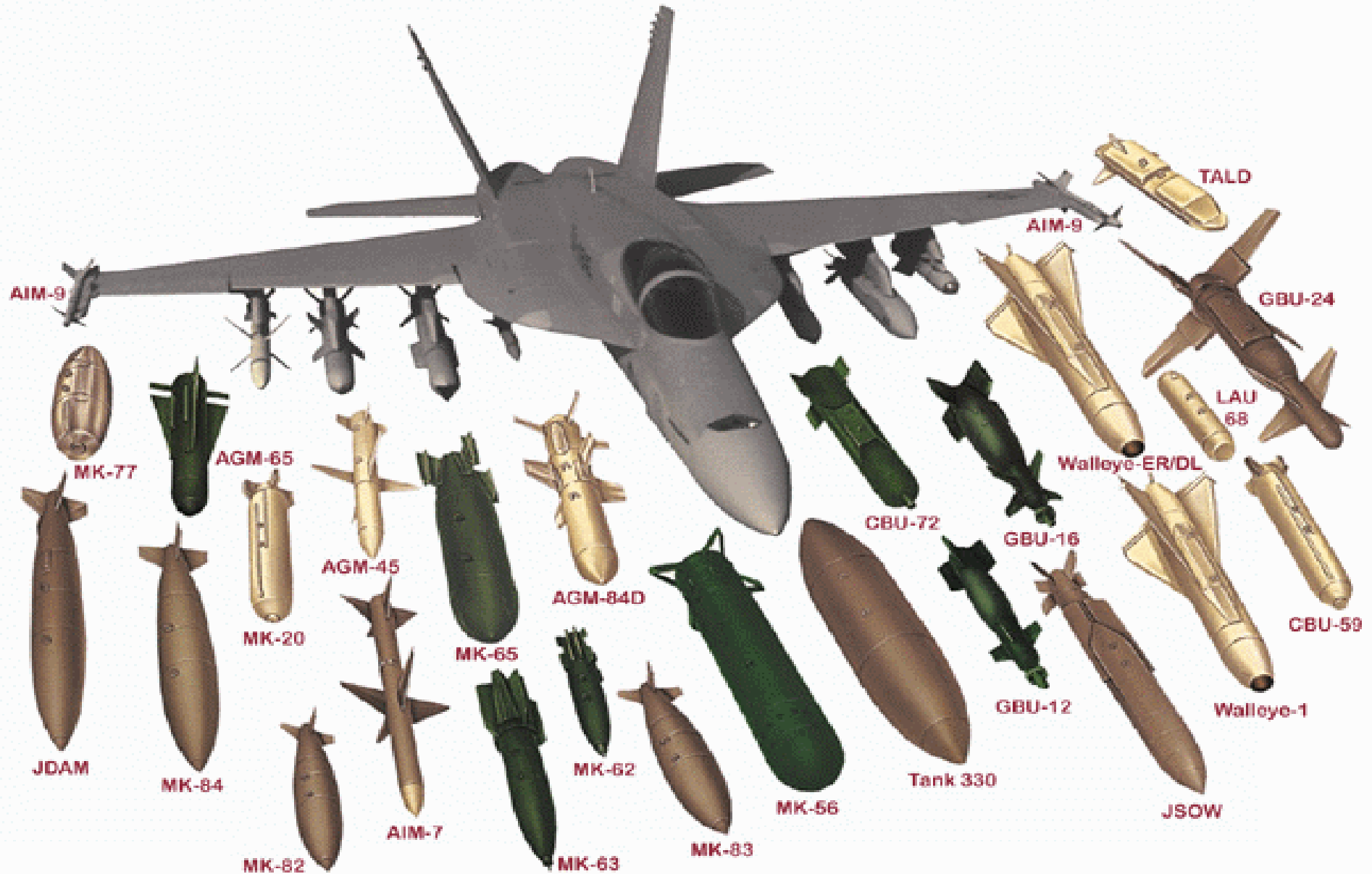



Test Development



- **Fleet Requirement**
-What is needed by the Warfighter?
- **Flight Clearance Request**
-Testers request flight envelope to fly.
- **Matrix Development**
-Testers work with Stores Separation Engineers to develop safe, efficient test matrix.
- **Data Collection**
-What tools can the Tester use to collect the required data?





Timeline



- Testing vs Windtunnel
 - Testing is efficient but can be expensive with flight hour costs
 - Windtunnel has long lead time but if test points can be deleted, saves money
- Save money vs time
 - Program managers decide what trade-offs are taken in the test program
- Priority
 - Fleet priority sometimes dictates how fast the timeline runs
- Value of asset
 - New store or expanding the capabilities of an existing store?



Flight Clearance

Engineering Flight Clearance Review

- Flutter
- Dynamic Store Release
- Noise and Vibration
- Loads
- Hazard to Electromagnetic Radiation for Ordnance (HERO)
- EMC
- System safety
- Aircraft Performance
- Flying Qualities
- Stores Separation
- Flight Controls
- Strength
- Ground loads



Matrix Development



- **Wind Tunnel**
 - data collected for various Mach/Airspeed combos
- **Computational Fluid Dynamics (CFD)**
- **Historical Data**
 - Similar store data (qual/quant) available?
- **Flight Test**
 - Has the store been flown on the aircraft before?
 - Risk? Store Cost? Envelope? Configuration?

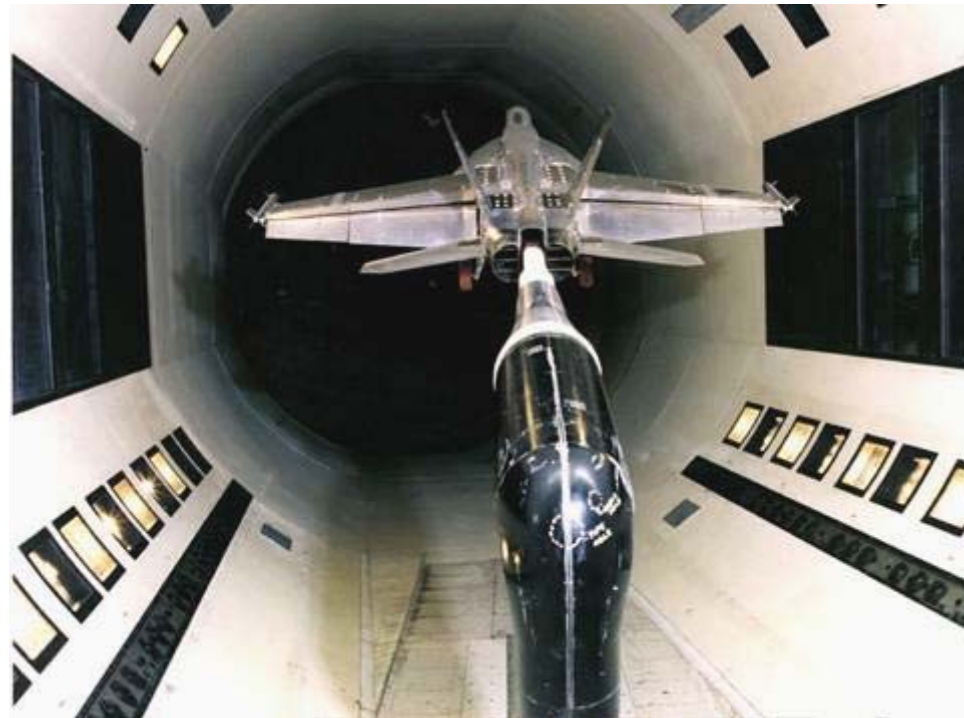



Separation Flight Test



- Data Collection for Aircraft and Store
 - High Speed Film Cameras
 - Facilitates Photogrammetric Solution
 - Received post-flight
 - Airborne Separation Video System (ASVS)
 - Viewed real time, downloaded minutes after separation
 - Six Degree-of-Freedom Package (6DoF)
 - Telemetered real-time to control room to view and record
 - Aircraft MUX Instrumentation
 - Telemetered real-time to control room to view and record
 - HUD Tape and Pilot Observations
- External Cameras
 - Tracking Mounts / Theodolites
 - Chase Photography



ASVS Example





6DoF Units



6DoF Unit installed in Nose of MK-80 Series Bomb

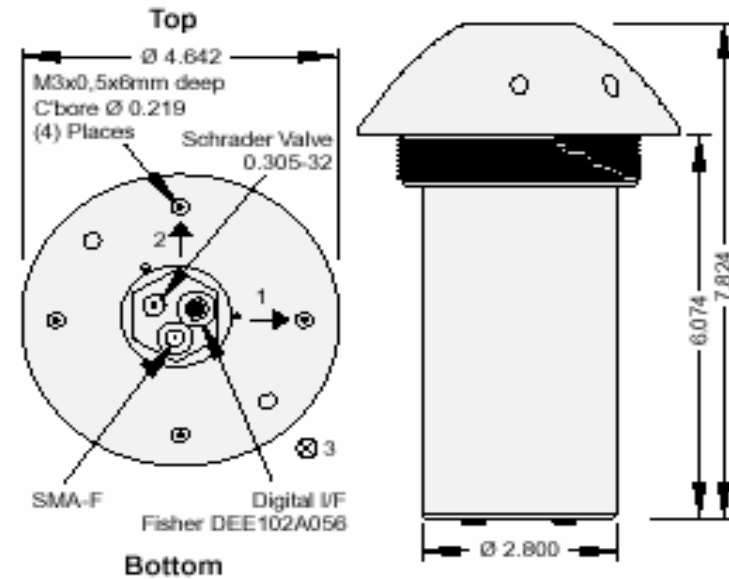

6DoF Schematic

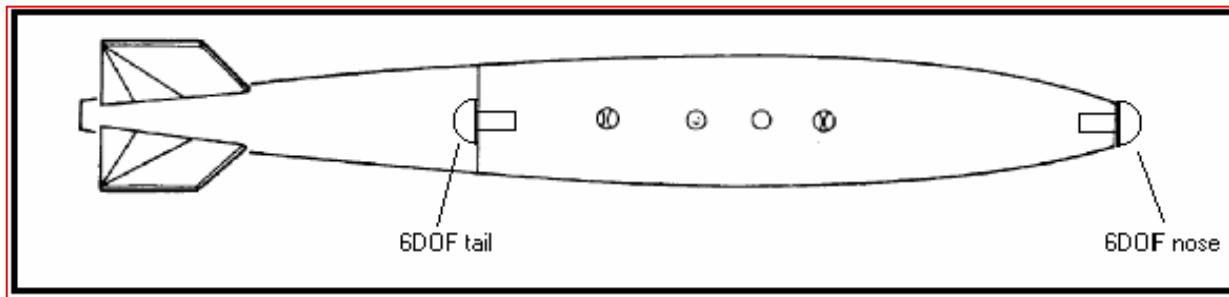

6DoF Installation Positions on MK-80 Series Bomb



Range Facilities



Theodolite Camera



KTM Tracking Mount



Project Engineer Stations



Range Facilities (cont.)



- Range Instrumentation Division
 - Develops & operates real-time and post-processing range instrumentation systems.
 - Range Control Center provide real-time control of test missions.
- Time Space Position Information Division
 - Video processing and display systems
 - Radar, Global Positioning System (GPS), optical, metrology and meteorology.
- Telemetry Data Center
 - Real-time reception, translation and processing of telemetry data using the Real-Time Telemetry Processing System (RTPS).



Safety Chase





Post Flight Data Reduction



- Match wind tunnel model
 - Do store positions and rates match predicated values?
- Possibility to delete a test point
 - If tunnel matches flight test data, delete test points without jeopardizing safety
- Matrix Development and Refinement
 - Amend matrices based on data from both tunnel and flight data
 - Increase or decrease test point parameters to test the store at specific points in the sky
- Test to Worst Case Scenarios
 - Test until desired envelope is reached or safe separation is compromised



Post Flight 6DoF Data

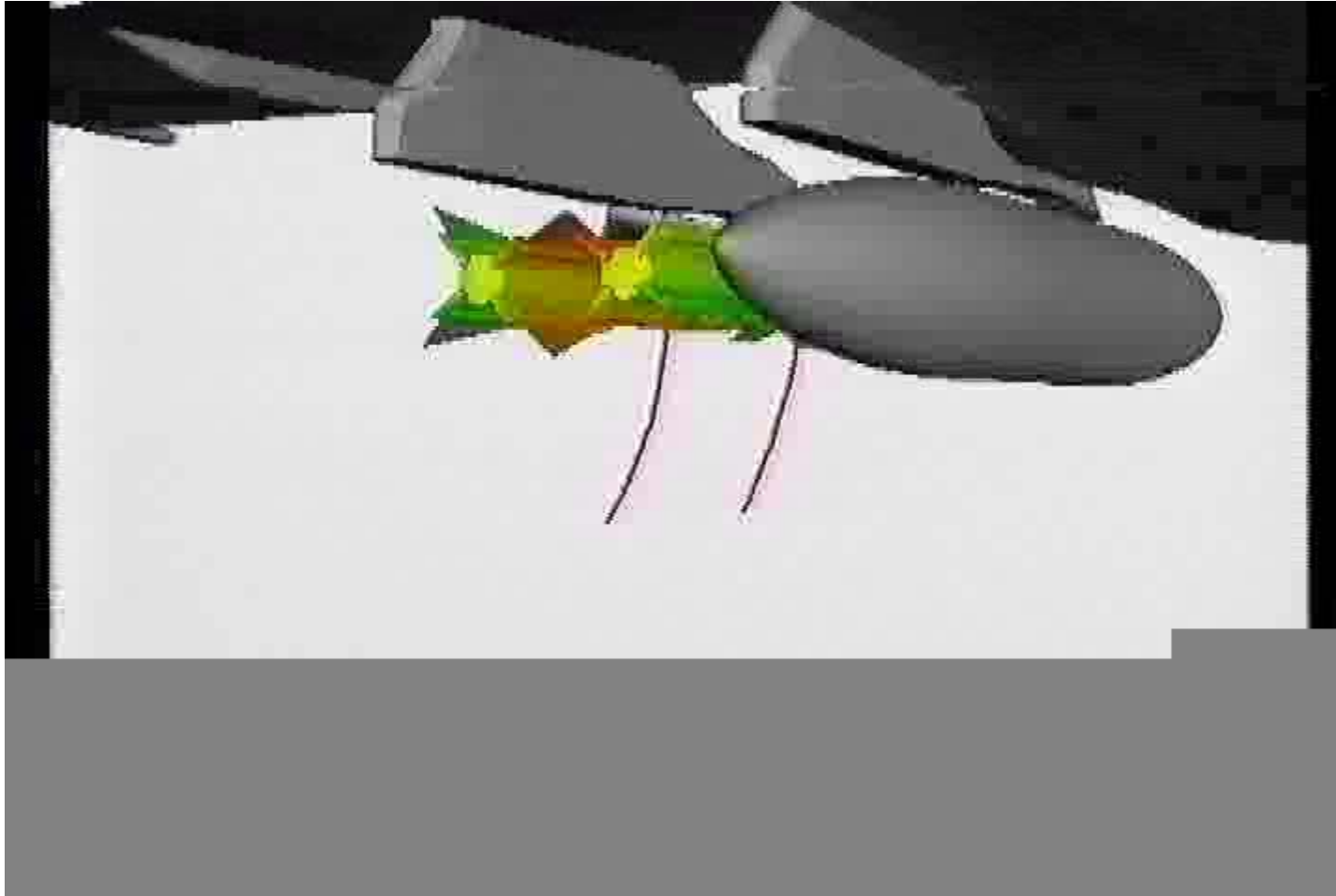



Post Flight 6DoF Data

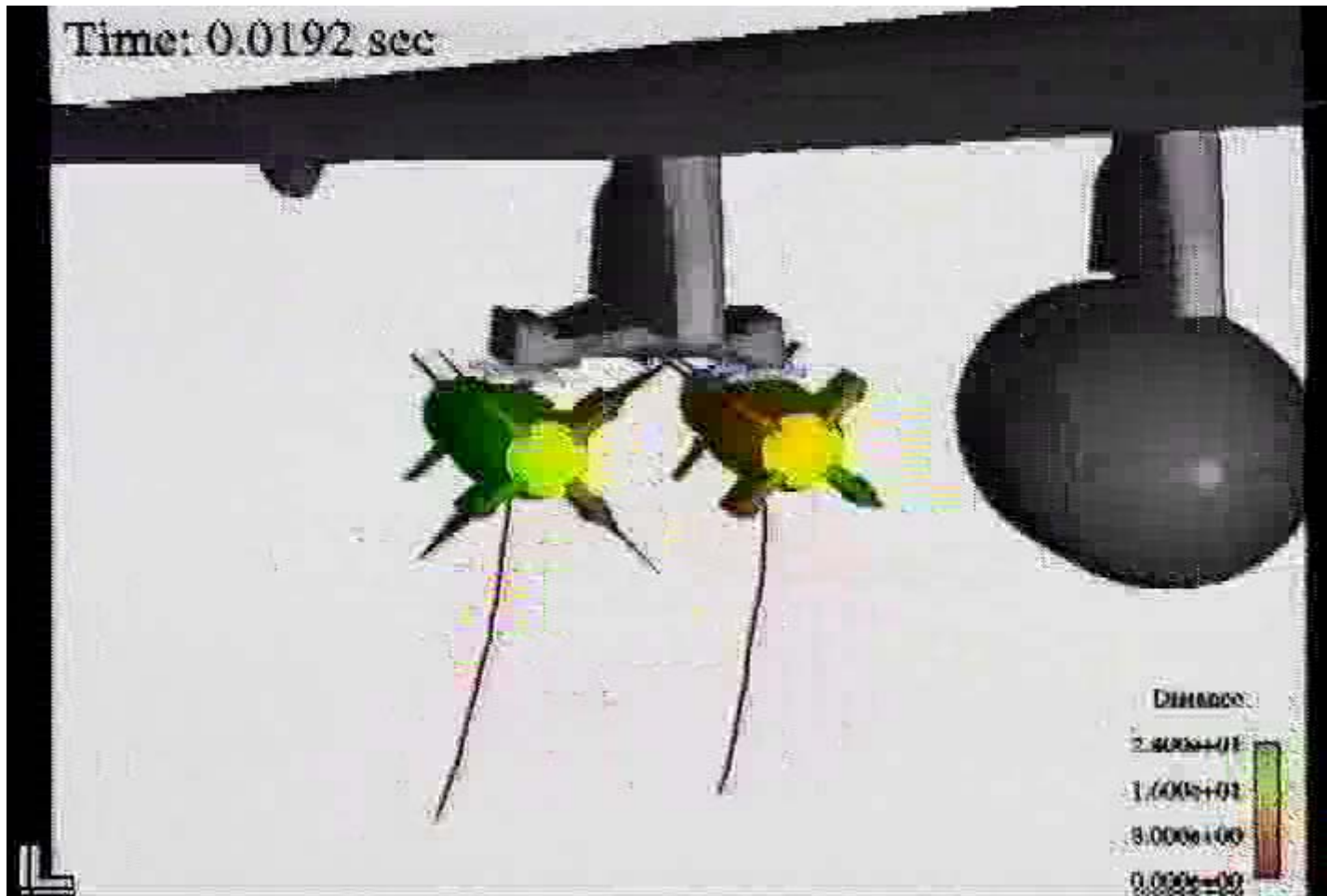



The Goal





Questions

