

Advanced control and safety unloading systems in use on the HAWK LIF FSFT

presented by:

*Graeme Burnett Consultant Engineer
Engineering Manager HAWK LIF FSFT*

prepared by:

*Graeme Burnett, Scott Dutton DSTO,
David Hartley DSTO, and Michael Sullivan MTS*



Australian Government
Department of Defence
Defence Science and
Technology Organisation

BAE SYSTEMS



MOOG

© Commonwealth
of Australia 2005

06 April 2005

Hawk LIF FSFT Control and Safety Systems

Aerospace Testing Expo Europe 2005

Content

- Hawk Lead-In-Fighter Full-Scale-Fatigue-Test
- Control and Data Acquisition System
- Safety Unloading System



Australian Government
Department of Defence
Defence Science and
Technology Organisation

BAE SYSTEMS

MTS

MOOG

06 April 2005

HAWK Lead In Fighter FSFT

Aerospace Testing Expo Europe 2005

Test Location



Australian Government
Department of Defence
Defence Science and
Technology Organisation

The Australian Defence Science and Technology Organisation is conducting a Full Scale Fatigue Test under contract to BAE SYSTEMS of the Hawk Mk127 Lead In Fighter airframe at the DSTO Fishermans Bend facility in Melbourne, Australia

BAE SYSTEMS



MOOG

06 April 2005

HAWK Lead In Fighter FSFT

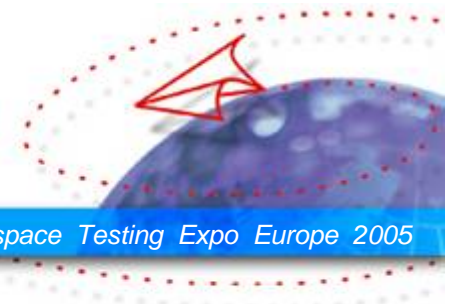

Aerospace Testing Expo Europe 2005



BAE SYSTEMS Hawk Mk127 Lead In Fighter

HAWK Lead In Fighter FSFT



Aerospace Testing Expo Europe 2005

90 Control Channels



84 hydraulic actuators
in load
or displacement
control



6 pressurised
volumes under
pressure control



Australian Government
Department of Defence
Defence Science and
Technology Organisation

BAE SYSTEMS



MOOG

06 April 2005

Hawk LIF FSFT Control and Data Acquisition

Aerospace Testing Expo Europe 2005

Control and DAS Hardware

- 96 Channels MTS Aero ST configured as four 24 channel chassis, mounted in two racks
- 1200 Channels of HBM Data Acquisition in two racks



Control and DAS Software

- MTS AeroPro™ 4.1 Software

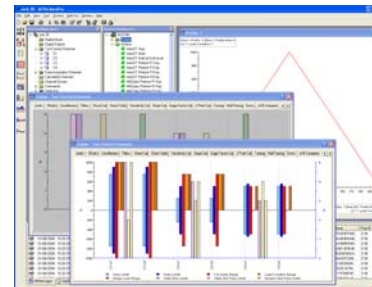

Australian Government
Department of Defence
Defence Science and
Technology Organisation

BAE SYSTEMS

MTS

MOOG

06 April 2005

Hawk LIF FSFT Control and Data Acquisition

Aerospace Testing Expo Europe 2005

MTS Aero ST Hardware

48 channel rack
Aero ST



600 channel rack
HBM Data Acquisition



Australian Government
Department of Defence
Defence Science and
Technology Organisation

BAE SYSTEMS

MTS

MOOG

06 April 2005

Hawk LIF FSFT Control and Data Acquisition

Aerospace Testing Expo Europe 2005

Simplified AeroPro Control Law Block Diagram

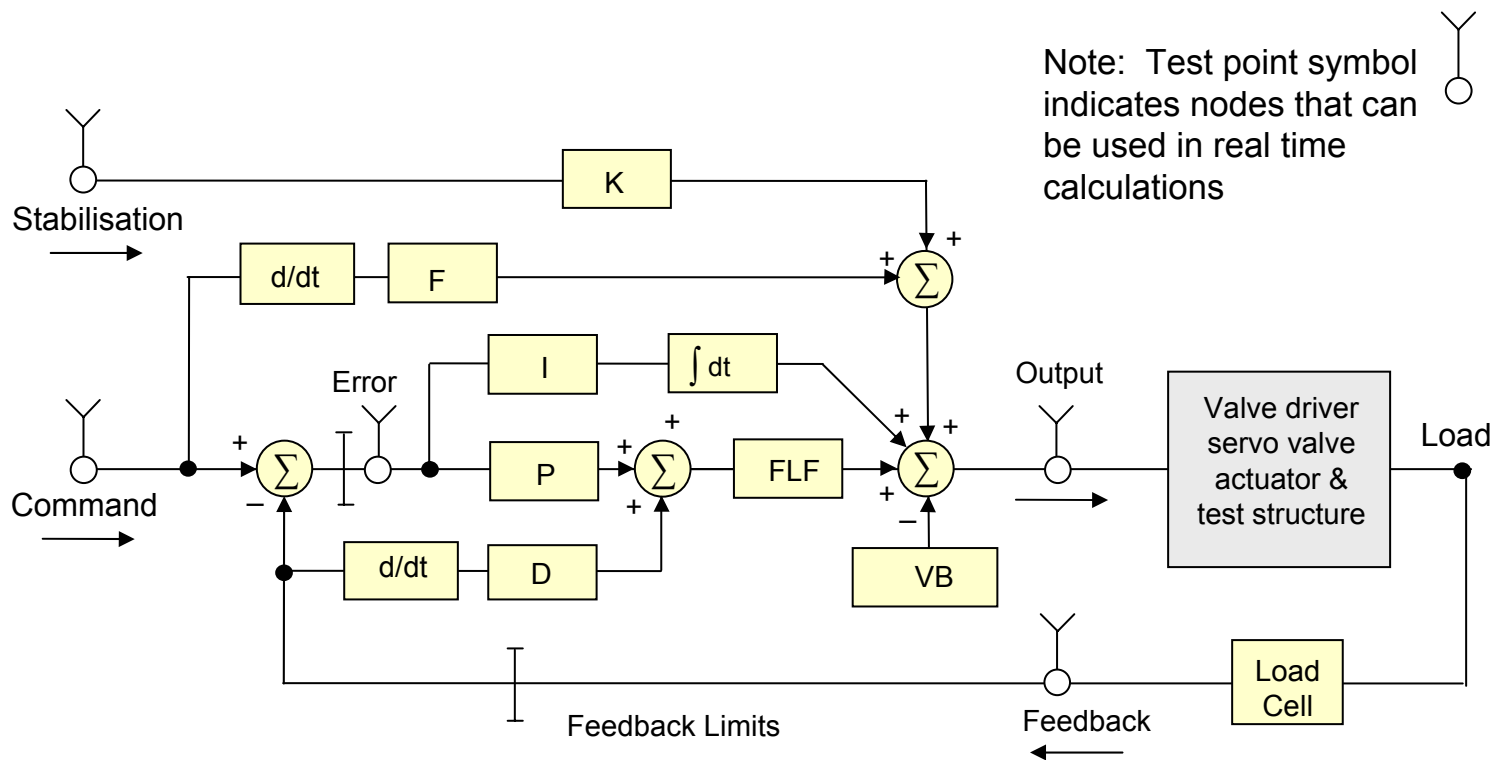

Note: Test point symbol indicates nodes that can be used in real time calculations



Australian Government
Department of Defence
Defence Science and
Technology Organisation

BAE SYSTEMS

MTS

MOOG

Legend: P – Proportional gain, I – Integral gain, D – Differential gain,
F - Feed-forward gain, K - Stabilisation gain , VB - Valve balance,
FLF -Forward Loop Filter

06 April 2005

Hawk LIF FSFT Control and Data Acquisition

Aerospace Testing Expo Europe 2005

Calculated Inputs and Outputs

- Attributes of virtual inputs and outputs:
 - calculated at system sync rate
 - functions of real inputs and outputs
 - functions of nodes from other control channels
 - functions of system states
- LIF FSFT Application:
 - custom control laws
 - real-time multi-channel interaction compensation
 - non-linear gain scheduling
 - reaction back-off



Australian Government
Department of Defence
Defence Science and
Technology Organisation

BAE SYSTEMS



MOOG

06 April 2005

Hawk LIF FSFT Control and Data Acquisition

Aerospace Testing Expo Europe 2005

Non Linear Gain Scheduling

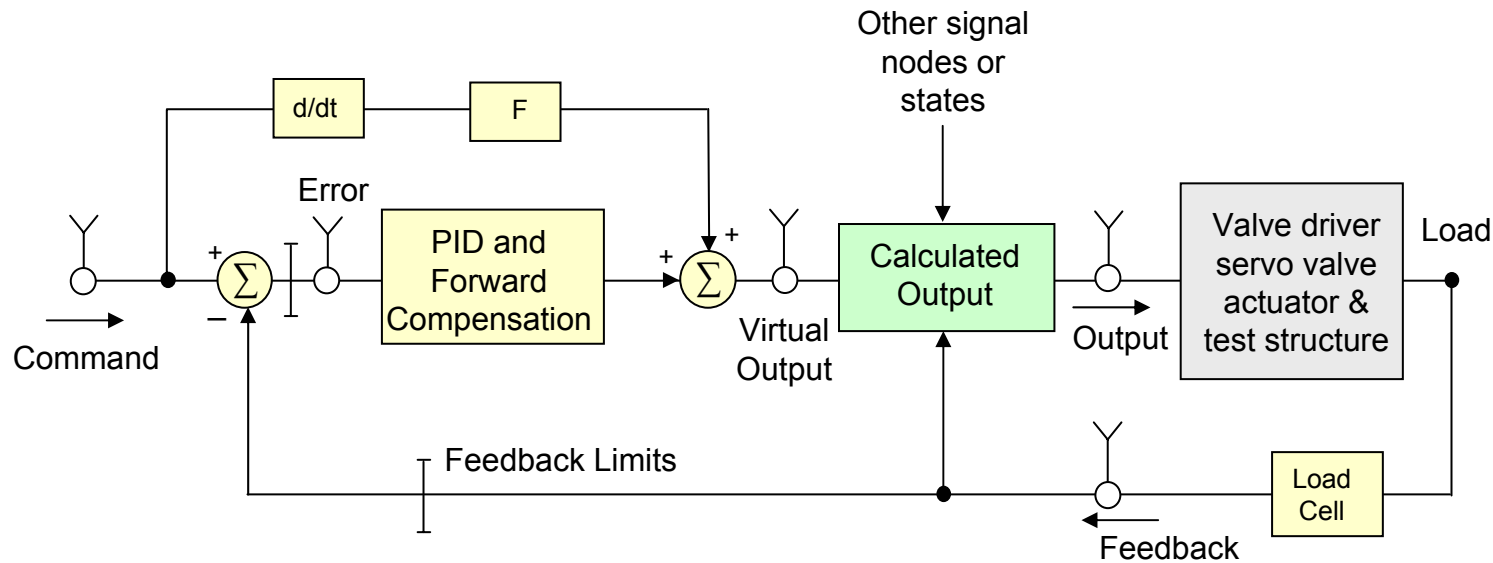

If the servo valve flow gain is a non-linear function of the feedback load, then a Calculated Output function can be derived so that the rate of change of Load is a linear function of the “Virtual Output” signal



Australian Government
Department of Defence
Defence Science and
Technology Organisation

BAE SYSTEMS



MOOG

06 April 2005

Hawk LIF FSFT Control and Data Acquisition

Aerospace Testing Expo Europe 2005

Real-time multi-channel feed-forward

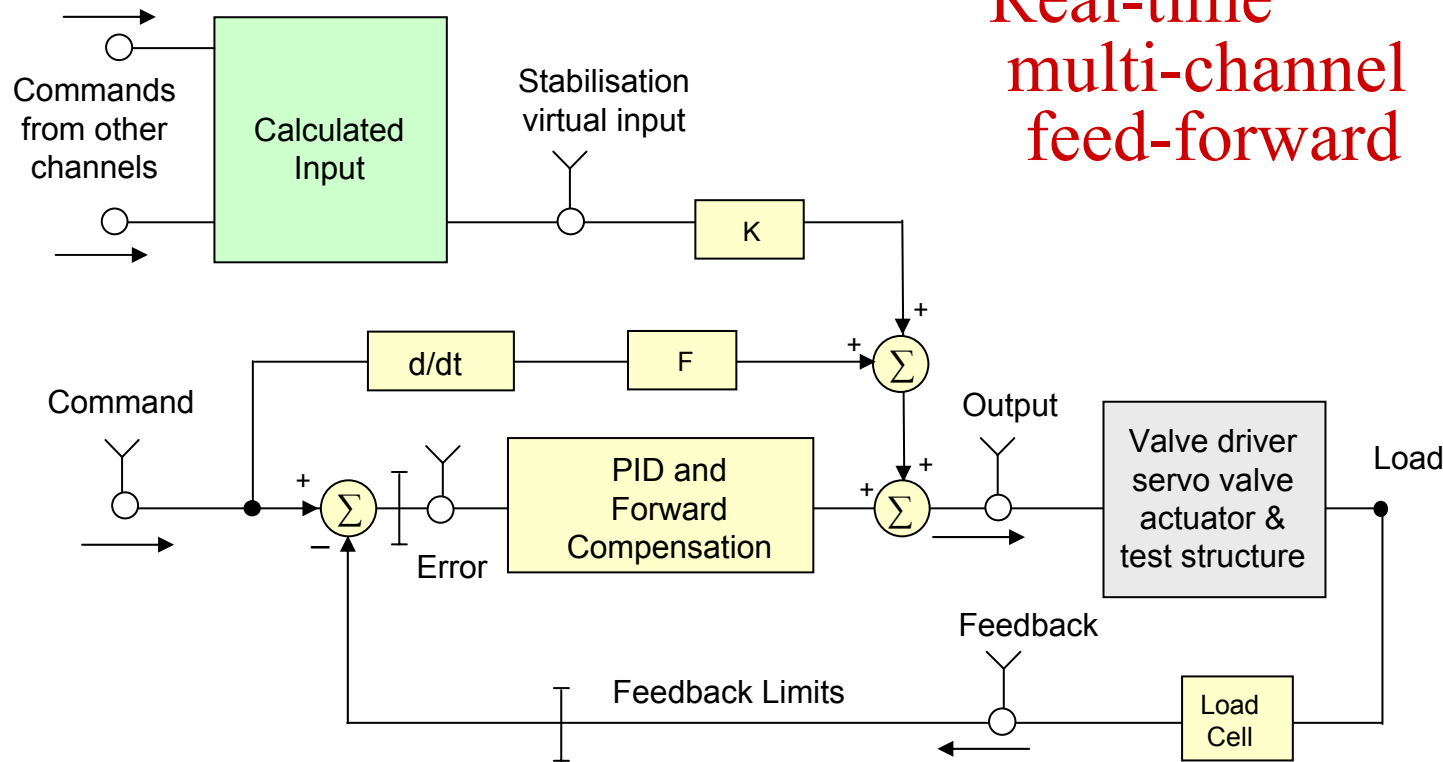

Australian Government
Department of Defence
Defence Science and
Technology Organisation

BAE SYSTEMS

MTS

MOOG

Where several other channels interact with a control channel, the effects of the interaction can be cancelled out by using a Calculated Input that is a weighted sum of the rate of change of the disturbance channel commands.

06 April 2005

Hawk LIF FSFT - Safety Unloading System

Aerospace Testing Expo Europe 2005

Unload System Hardware

- Two separate 48 Channel MTS Aero ST systems
- 90 MOOG Controlled Abort Manifolds
- 5 MOOG Passive Abort Manifolds



Unload System Software

- MTS Aero 793 Software with Multipurpose TestWare® Software

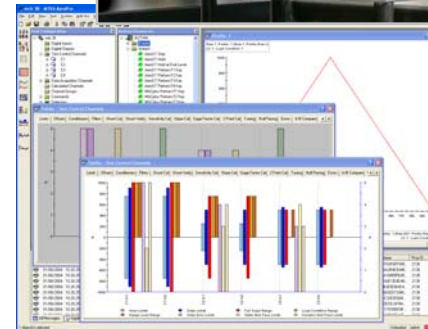

Australian Government
Department of Defence
Defence Science and
Technology Organisation

BAE SYSTEMS

MTS

MOOG

06 April 2005

Hawk LIF FSFT - Safety Unloading System

Aerospace Testing Expo Europe 2005

Primary Control and Unload System Block Diagram

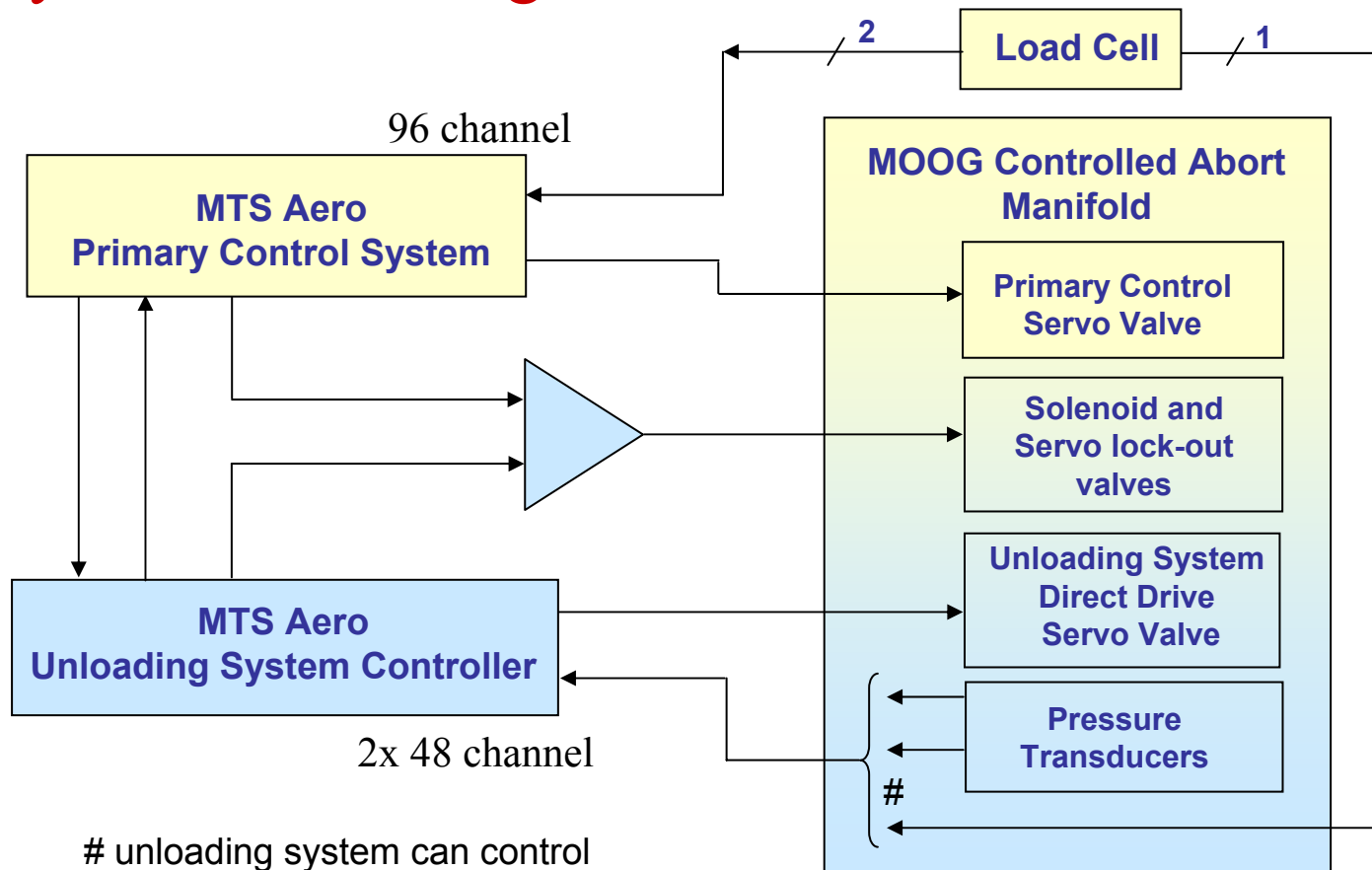

unloading system can control by load or differential pressure



Australian Government
Department of Defence
Defence Science and
Technology Organisation

BAE SYSTEMS



MOOG

06 April 2005

Hawk LIF FSFT - Safety Unloading System

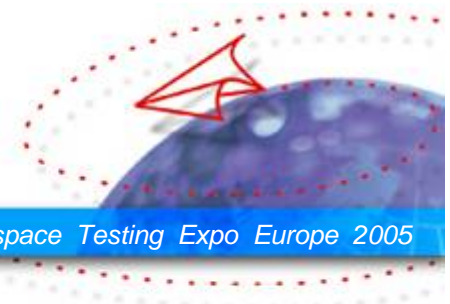

Aerospace Testing Expo Europe 2005

MOOG Australia – Controlled Abort Manifold



Based on DSTO passive unload valve pack,
common manifold for the controlled abort and passive abort models



Australian Government
Department of Defence
Defence Science and
Technology Organisation

BAE SYSTEMS

MTS

MOOG

06 April 2005

Hawk LIF FSFT - Safety Unloading System

Aerospace Testing Expo Europe 2005

CAM Hydraulic Circuit

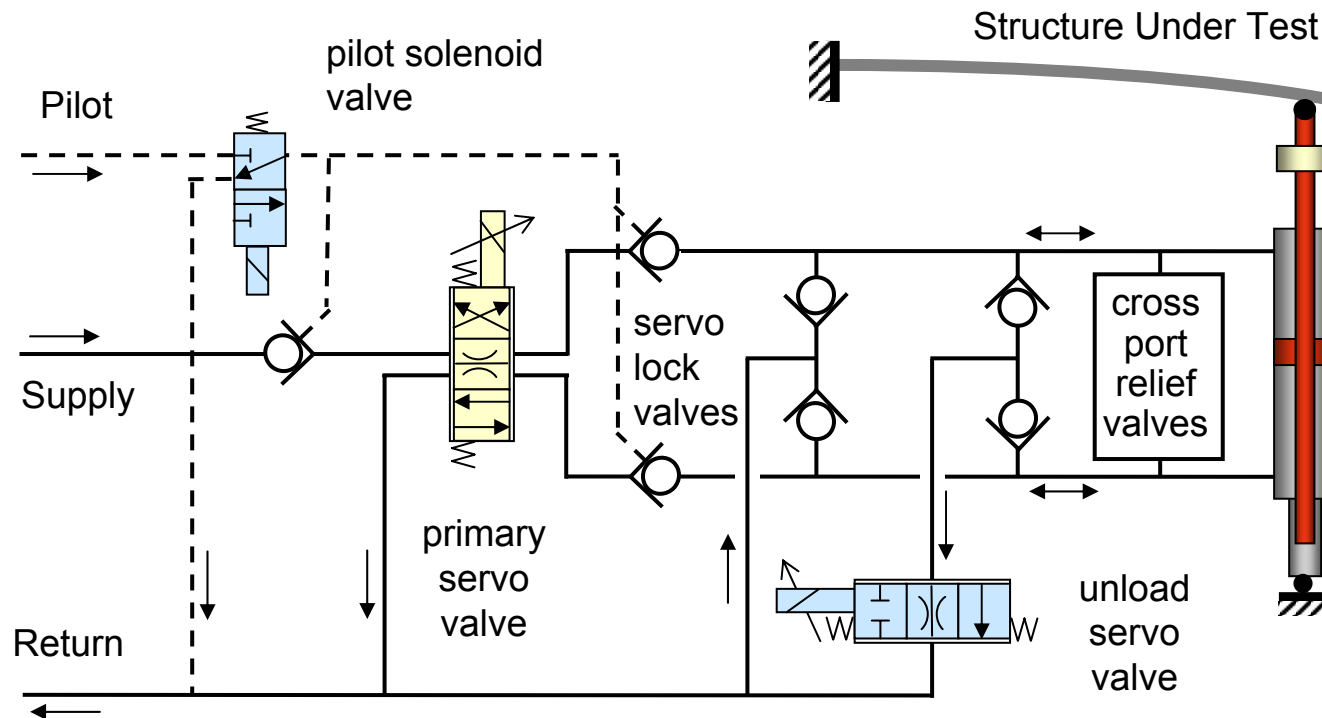

Loss of pilot pressure or de-energising pilot solenoid switches from primary control to unload control



Australian Government
Department of Defence
Defence Science and
Technology Organisation

BAE SYSTEMS

MTS

MOOG

06 April 2005

Hawk LIF FSFT - Safety Unloading System

Aerospace Testing Expo Europe 2005

Controlled Unload Schematic Diagram

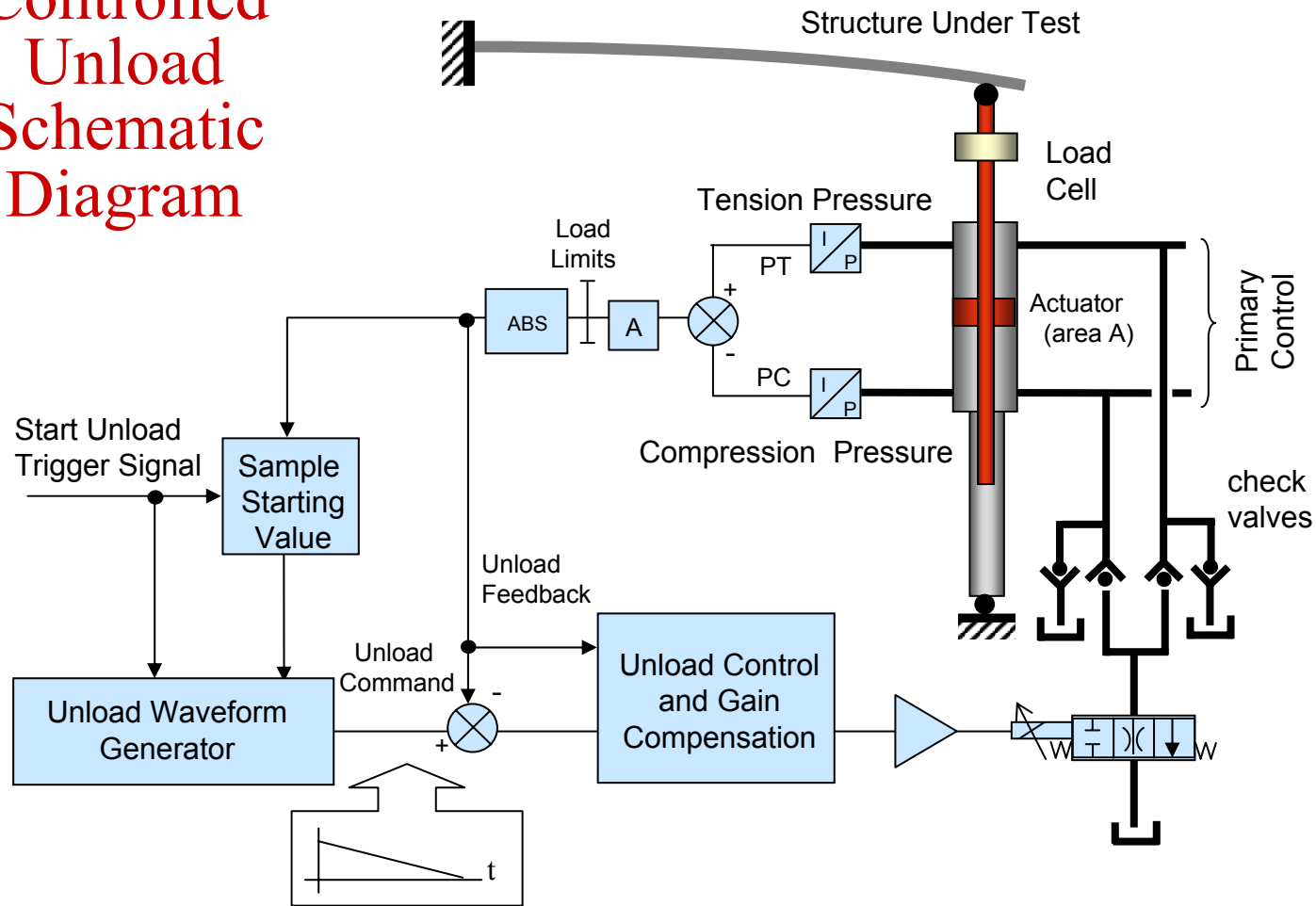

Australian Government
Department of Defence
Defence Science and
Technology Organisation

BAE SYSTEMS

MTS

MOOG

06 April 2005

Hawk LIF FSFT - Safety Unloading System

Aerospace Testing Expo Europe 2005

Controlled Unload Waveform

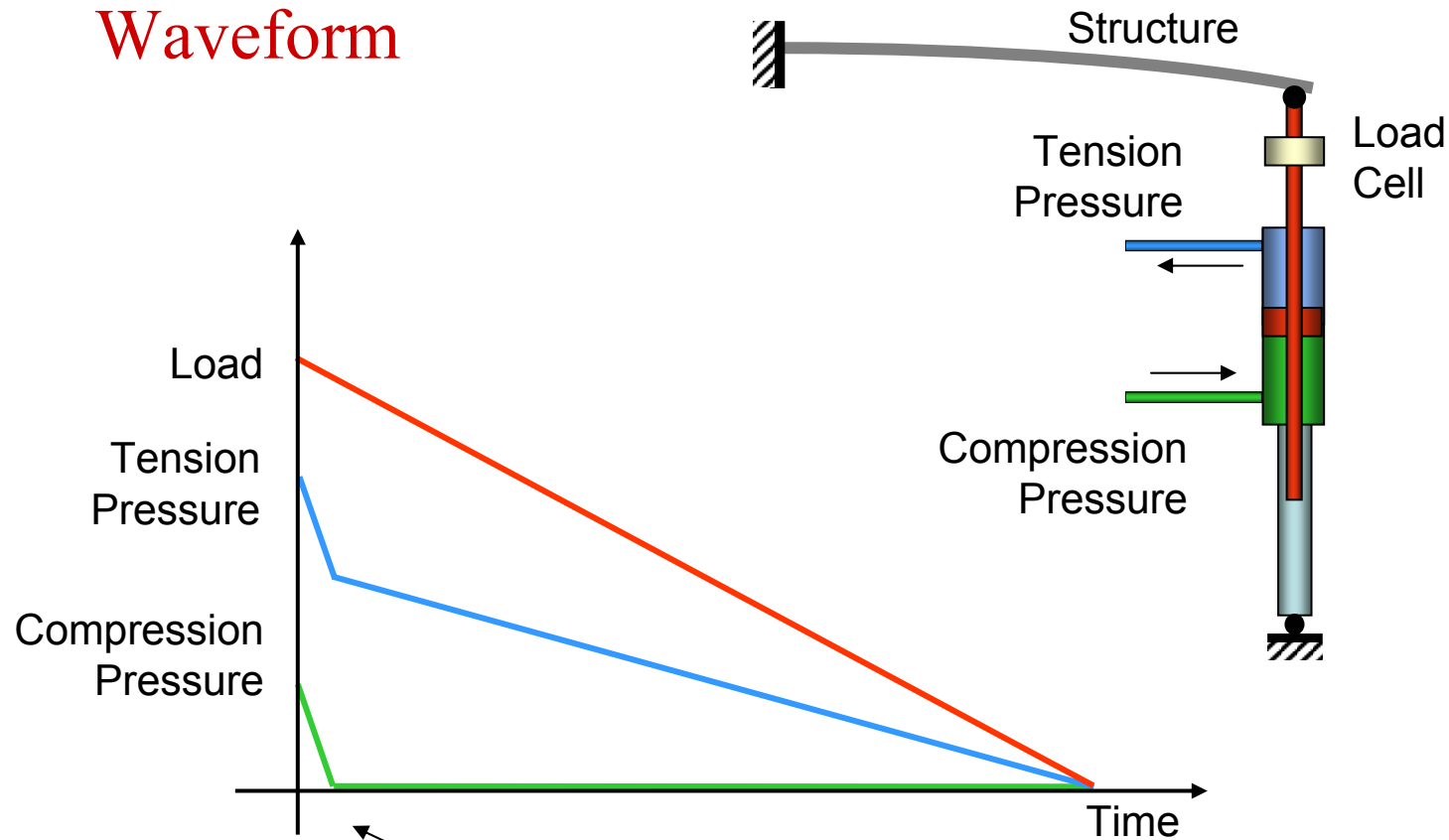

Initial movement causes one chamber to drop to zero pressure



Australian Government
Department of Defence
Defence Science and
Technology Organisation

BAE SYSTEMS



MOOG

06 April 2005

Hawk LIF FSFT - Safety Unloading System

Aerospace Testing Expo Europe 2005

Multi-channel Spring Rig

- Two Channel Primary Control
- Two Channel Controlled Unload
- Variable stiffness pneumatics
- MTS Flextest GT controller
 - Development work
 - Commissioning subsystems
 - Operator Training



Australian Government
Department of Defence
Defence Science and
Technology Organisation

BAE SYSTEMS

MTS

MOOG

06 April 2005

Conclusion

Aerospace Testing Expo Europe 2005

New Developments Featured on Hawk LIF FSFT

- First multi-box MTS Aero ST / AeroPro System
- Improved control law compensation and valve balancing
- Calculated inputs and outputs to customise control laws
- Test data in a long term XML data archiving format
- MTS / MOOG controlled unload system

Note: DSTO has been either a contributor to many of these developments or has been involved with testing and validation of these new capabilities.



Australian Government
Department of Defence
Defence Science and
Technology Organisation

BAE SYSTEMS



MOOG

06 April 2005

HAWK Lead In Fighter FSFT

Aerospace Testing Expo Europe 2005

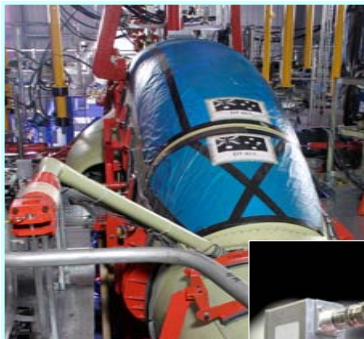

Questions?



Australian Government
Department of Defence
Defence Science and
Technology Organisation

BAE SYSTEMS



MOOG

06 April 2005

HAWK Lead In Fighter FSFT

Aerospace Testing Expo Europe 2005

© Commonwealth of Australia 2005

Approval is required to reproduce any HAWK LIF FSFT material from this presentation through the DSTO-LIF-FSFT Project Office, Platforms Sciences Laboratory, Defence Science and Technology Organisation, Australia



Australian Government
Department of Defence
Defence Science and
Technology Organisation

BAE SYSTEMS



MOOG

06 April 2005